

Disco Madness

The Whys & Wheres of Disconnects

by John Wiles

Sponsored by the U.S. Department of Energy

In the event of an emergency, disconnect switches are used to rapidly disconnect the external power source conductors from the circuits in a building or structure (*National Electrical Code* Sections 690.13; 230.70). A common disconnect of this type is the AC service entrance disconnect for a house. Utilities require disconnects on grid-tied PV systems to protect their workers from possible electrocution.

Disconnects also are required on individual PV components so that power can be interrupted to them during service—including maintenance or repairs. Another option would be to open all of the main power disconnects to remove all power from a building, but disconnects associated with single components can provide a degree of safety without shutting down the entire electrical system (Section 690.15). Be aware that in this case, some circuits in the system will still be energized and may be near de-energized circuits being serviced. The general *NEC* requirements for these disconnects are discussed below, but the local jurisdiction may stipulate something different.

Disconnected Scenarios

Switches, circuit breakers, screw terminals, and bolted connections all fall under the definition of “Disconnecting Means” in Article 100 of the *NEC* (see also *NEC* Section 690.17). To satisfy *NEC* requirements, disconnects must be accessible switches or circuit breakers without exposed, live parts, and rated for the nominal system voltage and available current. They also must plainly indicate whether they are in the opened or closed position.

The *NEC* specifies several types of disconnects, depending on the type of system and components involved.

- Many utilities require a **lockable, open, visible-blade AC disconnect** for the PV system. This disconnect is typically located near the utility’s KWH meter. The AC point of connection will require a disconnect on utility-interactive systems [Section 690.64(B)(1)].
- Contrary to the understanding of some inspectors, **there is no requirement for a disconnect at the PV array itself** [690.14(C)(5)]. Such a disconnect serves no safety purpose for the user or PV installer, since a PV array is always energized when illuminated—even if the disconnect were opened.
- A **main DC PV disconnect** is required where the PV DC circuits from the PV array enter the building (Section 690.13; 690.14). On a PV system, the main PV DC disconnect

falls into this category if the PV DC conductors penetrate the house. Although batteries are not power generators, they can source energy, so a battery disconnect might also fall into this category.

- A **main AC PV disconnect** is required for cases in which the DC PV circuits do not enter the building, but the AC output of the inverter does. You won’t find this requirement explicitly listed in Section 690, but the diagrams show this scenario in detail.
- A **DC inverter maintenance disconnect** is required; more than one may be required if the system has batteries (Section 690.15).
- An **AC inverter maintenance disconnect** is required for utility-interactive inverters (690.15).
- A **battery disconnect** is normally required on off-grid, battery-based PV systems or grid-tied (utility-interactive) PV systems with battery backup. In situations where batteries are located in a separate room or at some distance (5 feet or more) from the inverter and charge controllers, a second disconnect is required at the battery location, and this disconnect is usually merged with an overcurrent protection device.
- **Charge controller input and output disconnects** are required for maintenance on systems with batteries. (690.15)
- Battery-based inverters with generator inputs may also require a **generator disconnect** at the inverter input (690.15). Systems with backup generators will normally require a generator disconnect both outside, at the generator location (“point-of-entry power disconnect”), and inside, near the inverter and other power-processing equipment (“maintenance disconnect”).

Although there are two separate requirements for disconnects, in some cases a single disconnect, properly rated and located, may meet both conditions. In other situations, due to equipment placement and the necessity for grouping the maintenance disconnects, two or more disconnects may be needed in a single circuit (690.15).

Location, Location, Location

The original intent of the requirements for PV disconnects was to match them with the existing requirements for the AC service disconnects as established by Article 230. In fact, 690.14 in the 1984 *NEC* referred the reader directly to Article 230, Part F. Unfortunately, most PV installers did not follow this guidance.

In this era, most installers weren't familiar with installing AC service entrance conductors and service disconnects. Energized PV source- and output-conductor roof penetrations were commonplace, and conductors were routed to the main DC PV disconnect just about anywhere in the structure. Complaints from electricians and electrical inspectors prompted a rewrite of Section 690.14 in the 2002 NEC. In this revised section (which mimics 230 Parts IV & V), the requirement was firmly established to install the

PV disconnect in a readily accessible location at the point where the PV conductors first penetrate the structure. This requirement effectively keeps the energized PV conductors outside the structure until reaching that disconnect. Emergency response personnel assume that when the meter is removed, or when the main AC disconnect is turned off, that all electrical circuits inside a house or other structure will be de-energized ("dead"). If energized ("live") AC or DC circuits are in the house and are not affected by the main

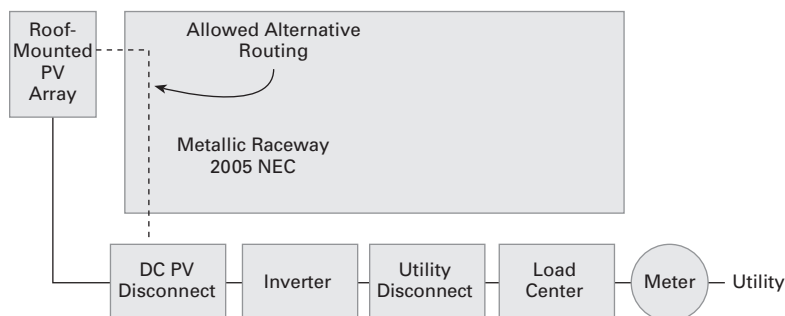

Fig. 1 shows the simplest configuration of a utility-interactive PV system in which the local jurisdiction requires all disconnects to be located outside the building. In this situation, the AC load center and inverter are also both mounted on the outside of the building.

Fig. 2 shows the main load center, with backfed PV circuit breaker, inside the building. In places where an external disconnect (usually lockable open) is required, the utility may also allow this disconnect to be used as the grouped AC maintenance disconnect for the inverter. If a utility disconnect is not required or it cannot be used as a code-required maintenance disconnect, then a separate AC disconnect needs to be mounted in this circuit next to the inverter on the outside of the building.

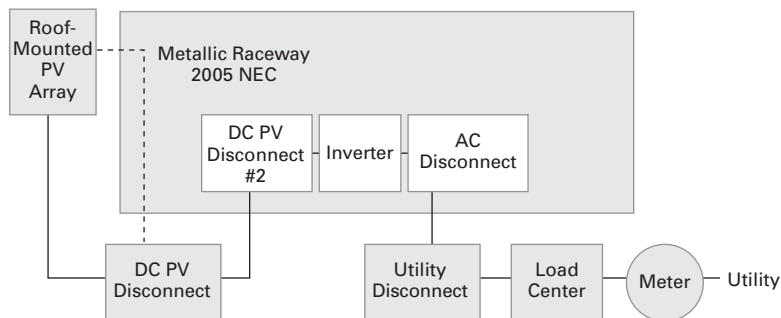
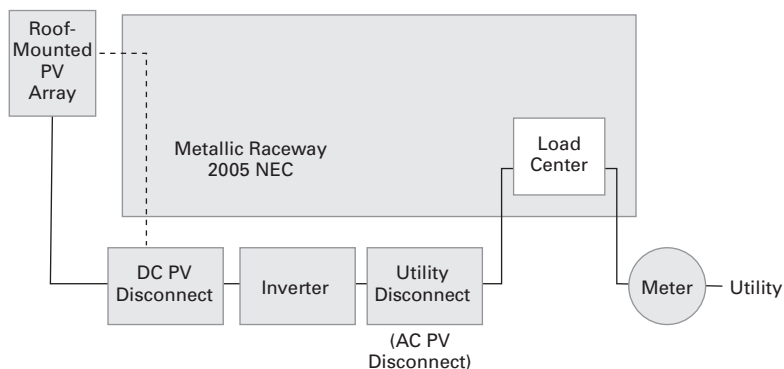
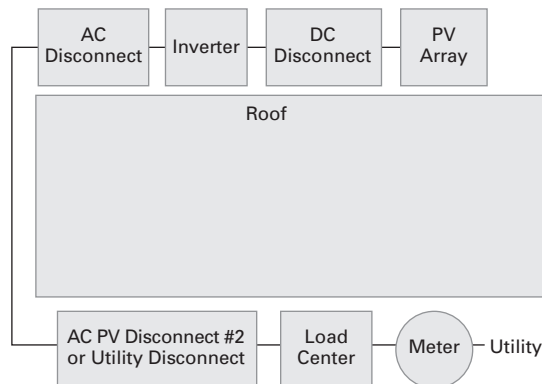

Fig. 3 reflects situations for which the local jurisdiction requires that the main AC and DC power disconnects (and the main load center containing them) be located outside the building, but for architectural reasons, the inverter be located inside the building. To provide for safe maintenance of the inverter, additional DC and AC maintenance disconnects are needed inside the building at the inverter.

Fig. 4 All of the equipment is outside the building for this system. In some roof-mounted PV installations, the inverters are mounted in not-readily-accessible locations near the PV arrays. Section 690.14(D) addresses these systems, and requires AC and DC disconnects at the inverters and an additional AC PV disconnect at ground level.



disconnect, then there is an electric shock hazard for these emergency response personnel.

The *NEC* does not specify whether the main AC service disconnect or the main DC PV disconnect should be located inside or outside the structure at the point of penetration of these circuits. That is left to the local jurisdiction—and the requirement for locating these disconnects varies throughout the country.

Section 690.31(E) of the 2005 *NEC* allows the PV source and output conductors to be routed inside the building (represented by the dotted line in the figures) before they reach the main PV disconnect, but only if they are installed in a metal raceway, which include rigid and flexible metal conduit. Metallic cable assemblies, such as and Type MC and Type AC cables, are not allowed yet.

Prescription for Disco Madness

Properly rated disconnects are required throughout a PV system in the code-required places. As the system complexity increases, with batteries, generators, and possibly wind- or microhydro-power inputs, the number of disconnects also increases. But the basic disconnect requirements were in the code long before PV systems arrived, and following those requirements as well as the newer requirements for PV systems will make for safe installations.

Other Questions or Comments?

If you have questions about the *NEC* or the implementation of PV systems that follow the requirements of the *NEC*, feel free to call, fax, e-mail, or write me at the location below. See the SWTDI Web site (below) for more detailed articles on these subjects. The U.S. Department of Energy sponsors my activities in this area as a support function to the PV industry under Contract DE-FC 36-05-G015149.

Access

John C. Wiles, Southwest Technology Development Institute, New Mexico State Univ., Box 30,001/ MSC 3 SOLAR, Las Cruces, NM 88003 • 505-646-6105 • Fax: 505-646-3841 • jwiles@nmsu.edu • www.nmsu.edu/~tdi

Sandia National Laboratories, Ward Bower, Sandia National Laboratories, Dept. 6218, MS 0753, Albuquerque, NM 87185 • 505-844-5206 • Fax: 505-844-6541 • wibower@sandia.gov • www.sandia.gov/pv • Sponsor

The 2005 *National Electrical Code* and the *NEC Handbook* are available from the National Fire Protection Association (NFPA) • 800-344-3555 or 508-895-8300 • www.nfpa.org

