

TO CONNECT OR NOT CONNECT -- THAT IS THE QUESTION

John Wiles

Photovoltaic (PV) modules have something in common with batteries -- they both can supply power even at times when it is not wanted. From a safety point of view, the National Electric Code requires that we be able to turn off or disconnect these sources of power at certain times to service or remove equipment in the PV system. As PV users, we must not only be aware of safety, but also of performance, cost in the design, & selection of disconnect components for our alternate energy systems.

Safety

The code requires that as a minimum we have a disconnect on both the PV array and the battery and any other source of power in the system such as a backup generator, hydro plant, wind machine or other battery charger. The disconnects shall be marked and grouped together. In a multiple source system, no more than six motions of the hand can be used to disconnect all sources of power. This last requirement may mean that multipole disconnects must be used. A disconnect can be, depending on location, either a switch, bolted connection, or terminal strip. In a grounded system, the positive conductor disconnects should be appropriately rated dc switches. The grounded conductor (normally negative) should never be broken with a switch and should have disconnects made with bolted connections. In floated PV systems which are not grounded (less than 50 volts open circuit array voltage), both conductors to the PV array and the battery or other source must be disconnected with a two-pole switch.

Performance

When disconnecting the battery, we need to make sure the PV array does not remain connected to the load because without the regulating feature of the battery, the high open circuit PV voltage might damage various electronic devices like fluorescent lamps and computers. Some charge controllers are sensitive to the connect and disconnect sequence and some wind machines need constant loads or they will be damaged. These requirements dictate that our switches must be placed very carefully.

Figure 1 shows a possible disconnect system for a small to medium size grounded PV system. Ampacity of the conductors and rating of the overcurrent devices will be determined by the number of modules and the load. A two-pole switch is used to disconnect both the input and output of the charge controller at the same time and two separate conductors are run to the battery so the load cannot be connected directly to the PV array.

Low Resistance Connections

Care must be given to use good, low-resistance connections, terminal strips and connectors as well as the highest quality switches, circuit breakers, and fuse holders. When we combine the devices required for overcurrent protection, short-circuit protection and disconnects we can come up with a number of connections between our power sources and the

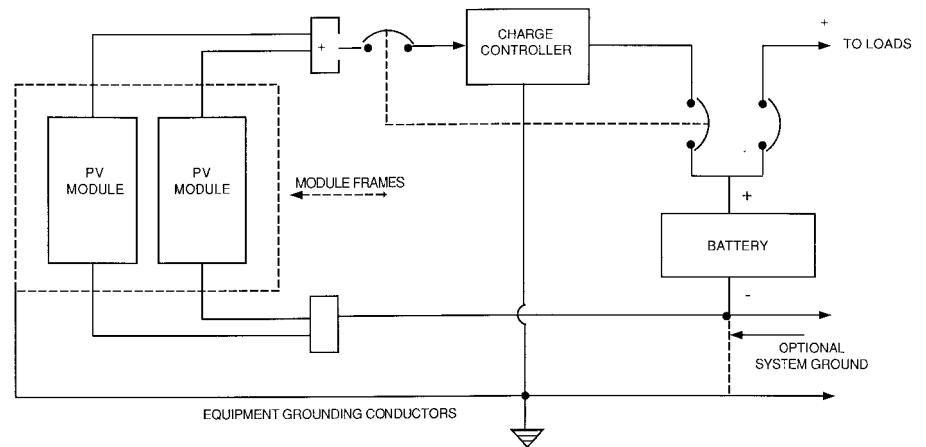

FIGURE 1 SMALL SYSTEM

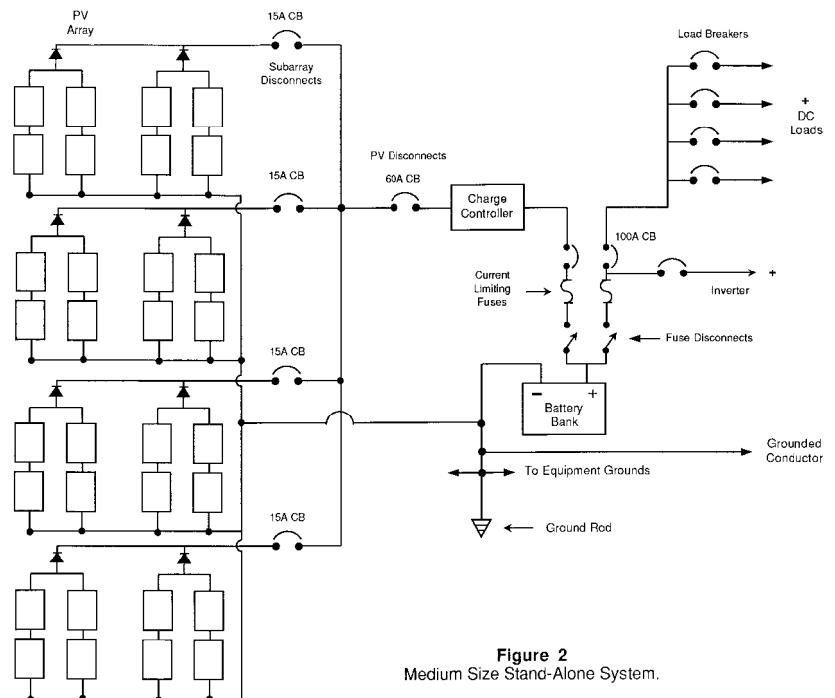

Figure 2
Medium Size Stand-Alone System.

loads. These connections, if not properly made, can create unwanted voltage drops and lost power even to the extent that the equipment will not work. Heavy duty copper terminals and connectors must be used especially in inverter circuits. Consideration should be given to combining the overcurrent function with the disconnect by using a circuit breaker instead of a fuse and switch. The number of contacts and connections will be greatly reduced and so will the

potential for excess voltage drops and power loss. With Square D QO residential breakers UL listed for 48 volts and up to 70 amps, there seems little reason to stay with separate fuses and switches which will cost more and possibly create reliability problems.

A Bigger Picture

Figure 2 shows the disconnects, overcurrent protection, and short-circuit protection for a medium size PV system. The rating of the overcurrent devices is shown as an example only and must be based on 125% of the PV short-circuit current for each separate location. Fuses and circuit breakers in the battery circuits are of course sized for the loads they must handle--see Code Corner in HP 16 & 17.

The 15 amp circuit breakers provide overcurrent protection for the smaller wires used to interconnect the modules and provides subarray disconnect capability. The conductors between these breakers and the 60 amp breaker must be sized to carry at least 60 amps or the 60 amp breaker will be unable to provide the proper protection. In this system, it is assumed that large, low-resistance conductors are being used to minimize the voltage drop and provide high levels of power to the inverter. These large conductors necessitate the use of the current limiting fuses to keep short-circuit currents under control. In the next Code Corner we will cover dc and ac distribution systems.

Access

John Wiles, SWRES, PO Box 30001/Dept 3SOL, Las Cruces, NM 88003 • 505-646-1846.



GIVE YOUR GENERATOR some MANNERS

The Sun Selector® **GenMate**™ generator controller can make your generator something you'll love.

Using the latest microcomputer technology, **GenMate** teaches your old generator new tricks.

GenMate works with nearly any electric start generator.

If your generator doesn't start itself when batteries are low, stop itself when batteries are full, and interface with the rest of your solar, wind, or hydro system automatically, you need **GenMate**.

Ask your Sun Selector dealer for information today.

Bobier Electronics, Inc.
304-485-6303

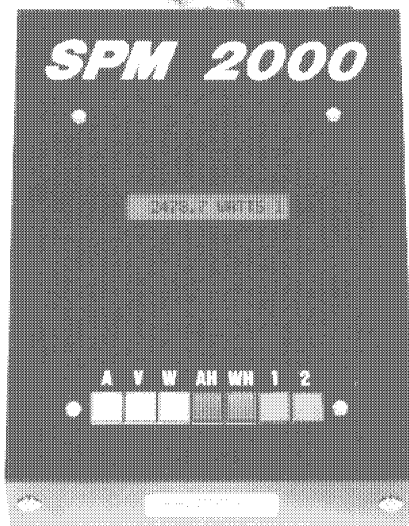

TWO CHANNEL AMP/HR TOTALIZER
2 CHANNELS-AMPS VOLTS WATTS AMP/HRS
WATT/HRS FUNCTION CHANNEL 1 & 2
CALL OR WRITE FOR A FREE SPEC SHEET
STEAMCO SOLAR ELECTRIC 2700 CANTU LN NW
BREMERTON, WA 98312 (206)830-4301

AUTOMAGIC BATTERY

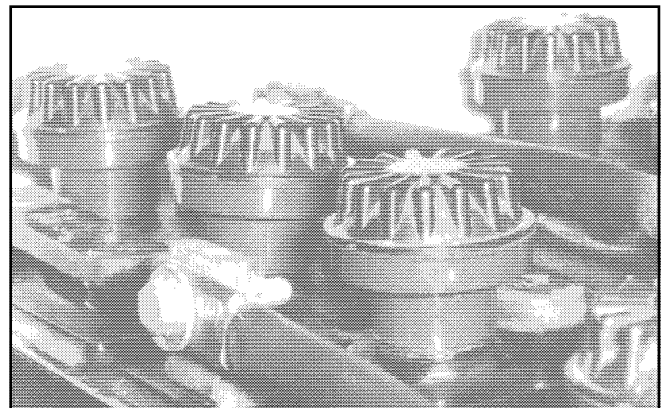

makes a good system almost maintenance free

THINGS THAT WORK! HP11

- Pure water returned to the battery cell
- Explosive hydrogen gas reduced
- Corrosion virtually eliminated
- Battery service life extended
- Safer battery operation
- Acid fumes greatly reduced
- Models available for NICADS.

Write or call for more information



Hydrocap
CATALYST BATTERY CAPS®

305-696-2504
975 NW 95 St.
Miami, FL 33150