

PV Grounding on a Single Dwelling

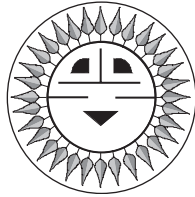

John Wiles

Sponsored by the Photovoltaic Systems Assistance Center,
Sandia National Laboratories

Properly grounding a PV system is one of the more complex tasks in meeting the requirements of the *National Electrical Code (NEC)*. In the *Code Corner* column in *HP72*, I covered the general requirements and definitions related to grounding. In this *Code Corner*, I'll present specific details for grounding a PV system where the PV modules are mounted on the roof of a dwelling and all equipment is contained in the same building.

Stand-Alone Systems

In a stand-alone PV system, there are no power connections to any electric utility. There is an energy storage system (batteries) and possibly a backup generator. Each of the grounding requirements for this type of system will be covered below (I'm assuming that the PV system is a grounded system—see *HP72*).

Section 690-5 of the *NEC* also requires that systems with PV modules mounted on the roof of a dwelling have ground-fault protection equipment. The Trace GFP-1 through GFP-4 are ground-fault protection devices that meet the requirements. Other equipment may also be available in the future. Some assembled power centers and panels include the ground-fault equipment. It is assumed, for purposes of discussing grounding, that the ground-fault protection equipment is being used and has been installed in accordance with the manufacturer's instructions.

Module Frame Grounding

The frames of listed PV modules will have a designated point to attach the equipment-grounding conductor. This is usually a special screw or lug marked with a green crosshatched arrow (the standard symbol for grounding). The equipment-grounding conductor for the circuit or circuits from the modules should be sized according to Table 250-122 in the 1999 *NEC* (Table

250-95 in the 1996 *NEC*). This table requires that the equipment-grounding conductor be sized according to the rating of the overcurrent device protecting the circuit. See the table below for some typical values from the *NEC* table.

The equipment-grounding conductor can be a bare wire, and usually will be if exposed in the outdoor environment. If it is insulated, it must have green insulation, but it is difficult to find wire with green insulation in a sunlight-resistant, outdoor-rated conductor. When the equipment-grounding conductor is routed in conduit, then green-insulated conductors like THHN/THWN-2 are commonly available. Bare conductors are also allowed in conduit.

The *NEC* allows the equipment-grounding conductor for DC circuits to be routed separately from the current-carrying conductors. A typical installation might look like Figure 1 and have the following parameters (these numbers are given as examples only). The circuit breaker or circuit breakers protecting the main circuits coming from the roof and located in the power center or main PV disconnect are 30–60 amps. A #10 AWG (5 mm²) bare conductor is connected from module to module using the equipment-grounding screw on each module. This conductor is then routed along the outside of the conduit to the PV combining box (if any) and then to the power center or other disconnecting means, where it is connected to an equipment-grounding screw.

If non-metallic sheathed UF or NM cable is used from the roof to the power center, the usual equipment-grounding conductor in this cable can be used. The equipment-grounding conductor from the modules may also be routed inside the conduit when an entry point to the conduit is available.

The equipment-grounding conductor from module to module should also be connected to the module mounting rack or frame. If there are smaller fuses or circuit breakers (4–20 amps) in the PV combiner box (used to protect the modules), it is possible to use smaller equipment-grounding conductors from the box to the module frames (as noted in the table).

Equipment Grounding Conductor Sizes

Overcurrent Device Amperage	AWG	mm ²
15	14	2
20	12	3
30	10	5
30	10	5
40	10	5
60	10	5
100	8	8

Figure 1: PV Module Equipment-Grounding Conductors for a Roof-Mounted PV Array

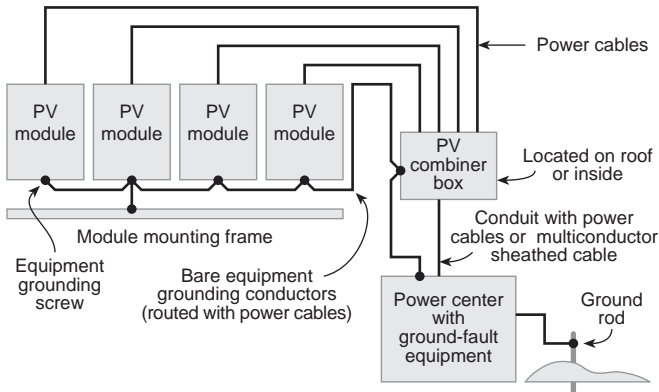

However, smaller conductors are more prone to physical damage and are required to have protection. I suggest #10 AWG (5 mm²) as the smallest gauge of bare conductor for equipment-grounding conductors for the exposed wiring to the PV modules. Even this size conductor must be protected from physical damage. In high lightning areas, other equipment-grounding techniques might be used.

Grounding of Other Equipment

In other circuits in the system, the equipment-grounding conductor must be sized according to the tables in the *NEC* (listed above). It must be based on the size of the overcurrent device protecting that circuit. For example, let's say the circuit breaker between the inverter and the battery is a 250 amp unit. The equipment-grounding conductor between the inverter and the circuit breaker enclosure, and also to any metal battery box or rack, should be a #4 AWG (21 mm²) conductor. A 400 amp fuse in this circuit would dictate a #3 AWG (27 mm²) equipment-grounding conductor.

The Grounding System

In any dwelling, the *NEC* requires any metal water piping and any metal gas piping to be tied to a grounding electrode. In most places, the grounding electrode is an eight foot (2.4 m) plated rod or pipe driven into the earth. The DC electrical system (and the AC electrical system connected to an inverter) must be connected to this grounding electrode system.

The actual connections from the ground rod to the DC and AC electrical system will vary from system to system. In most cases, all of the equipment-grounding conductors for the system will terminate at an equipment-grounding block and the grounding-electrode conductor will connect to this block. From that point, the grounding-electrode conductor will run to the ground rod where a listed clamp is used to connect it to the ground rod.

If there is only one conductor connected to the DC ground rod, then it may be as small as #6 AWG (13 mm²). If there are multiple conductors tied to the ground rod, then the DC grounding electrode conductor must be as large as the largest conductor in the system, which is usually a #2/0–4/0 AWG (67–107 mm²) battery cable.

The design of the ground-fault device will determine how the bond is made between the grounded current-carrying conductor and the grounding block. In most power centers and power panels, this bond is made at the factory.

AC System Grounding

In most stand-alone systems, the inverter includes an internal transformer that separates the DC system grounding from the AC system grounding. There will be an AC output from the inverter connected to an AC load center for the dwelling. There should be an equipment-grounding conductor connected between the inverter and the AC load center. This conductor will be sized based on the rating of the overcurrent device at the output of the inverter.

For example, the *NEC* requires a #10 AWG (5 mm²) equipment-grounding conductor when a 60 amp overcurrent device protects the circuit. In most cases, the AC load center will have a separate grounding electrode conductor and a ground rod. The equipment-grounding conductor between the inverter and the AC load center serves to bond the two ground rods together.

If the DC power center and the AC load center are near each other, it may be possible to use a single ground rod for both AC and DC grounding. In this case, there will be more than one grounding-electrode conductor connected to the ground rod. So the DC grounding-electrode conductor will have to be sized as large as the largest conductor in the DC system (usually the battery-to-inverter cable).

The size of the AC grounding electrode conductor will depend on the size of the conductor feeding the AC load center. A #6 AWG (13 mm²) conductor will serve as an AC grounding-electrode conductor for main AC power conductors up to and including #1/0 AWG (53 mm²) copper. A #4 AWG (21 mm²) grounding-electrode conductor will serve with power conductors up to #3/0 AWG (27 mm²). See 1999 *NEC* Table 250-66 (250-94 in the 1996 *NEC*) for additional values.

Systems with a generator also require an equipment-grounding conductor between the generator and the inverter. This conductor will be sized based on the rating of the overcurrent device at the generator. A 60

Figure 2: AC Grounding System

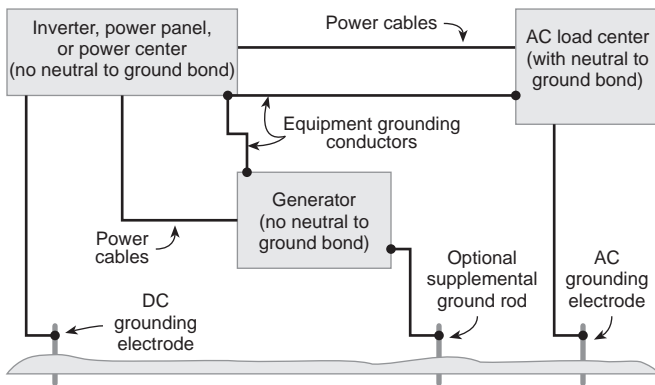

amp circuit will require a #10 AWG (5 mm²) equipment-grounding conductor. A 100 amp circuit requires a #8 AWG (8 mm²) equipment-grounding conductor. In some locations, a supplemental ground rod may be required for the generator and should be connected only to the generator frame (equipment-grounding system).

Neutral-to-Ground Bond

In the AC system, there should only be one connection between the AC neutral and the grounding system. This will normally be in the AC load center for the dwelling. Generator, inverter, power center, and power panel schematics, as well as manufacturer's literature, should be closely examined to determine that there are no neutral-to-ground connections in these devices.

The *NEC* requires the removal of additional (more than one) bonds that cause normal currents to flow in the equipment-grounding conductors. Qualified technicians should remove any unwanted bonding between the grounded conductor (usually the neutral) and ground. Figure 2 shows typical AC equipment-grounding connections and the grounding system.

In future *Code Corner* columns, grounding for other PV configurations will be addressed. These systems will include utility-interactive systems and systems where the PV array is ground-mounted away from the point of use.

The 2002 Code Cycle

Although the 1999 *National Electrical Code (NEC)* just became effective on January first of this year, complete and well-substantiated proposals for changes to the 2002 *NEC* are due to the National Fire Protection Association (NFPA) no later than 5 PM EST on Friday, November 5, 1999. This gives those individuals wishing to propose changes for the 2002 *NEC* less than three months to write and submit the proposed changes and the required substantiations. The correct form for submittal to the NFPA can be found in the back of the

1999 *NEC*. Electronic submissions may also be made. Contact NFPA for details.

Ward Bower at Sandia National Laboratories and a team of people from the PV industry (including utilities, vendors, installers, and users) will be working via email to write and substantiate proposals for the 2002 Code. A meeting is scheduled for October 7, 1999 in Tucson, Arizona. Contact Ward directly if you wish to participate in this activity. You can also send your ideas to me for entry into the system, if you provide, or we can develop, the necessary substantiation. Send your email address if you would like to receive information on the team's email deliberations on the 2002 *NEC*. For now, we have the following items under consideration:

- Figure 690-1: Label the energy storage.
- Section 690-5: Reword for clarity; possibly remove entire article.
- Section 690-6: Review ground-fault equipment requirements for AC PV modules.
- Section 690-7: Consider expanding for thin-film devices.
- Section 690-8: Add requirements or exceptions for low-power inverters.
- Section 690-45: Revise for PV source and output circuits.
- Section 690-8(b): Possible exception for current-limited devices.
- Section 690-31(b): Modify for clarity and technical correctness.
- Section 690-45: Reword or delete.
- Section 690-54: Reword for consistency.
- Section 690-64: Revise for utility-interactive systems in commercial buildings.
- Section 690-64: Remove restrictions on back-fed circuit breakers.
- Section H: Add prohibition on flooded, steel-cased batteries in systems operating over 50 volts.
- Section H: Consider a provision for ungrounding battery banks over 48 volts nominal (24 cells) for servicing.
- Section H: Specify labels for the battery system to include configuration, grounding, and polarity.

What are your ideas? Where have you had trouble with the code or with language not clear to electrical inspectors? What can be added or changed to make your job easier?

Please keep in mind that the *NEC* is a consensus document. If you participate with an input directly to NFPA, you will get a copy of all of the 2002 *NEC* proposals. You will also have a chance to comment on any of them and will get a copy of all of the comments on all of the proposals for the 2002 *NEC*. The proposal and comment documents weigh about eight pounds (3.6 kg) each and they include the deliberations, comments, and actions taken by each of the code making panels.

Questions or Comments?

If you have questions about the *NEC* or the implementation of PV systems following its requirements, feel free to call, fax, email, or write me. Sandia National Laboratories sponsors my activities in this area as a support function to the PV Industry. This work was supported by the United States Department of Energy under Contract DE-AC04-94AL8500. Sandia is a multi-program laboratory operated by Sandia Corporation, a Lockheed Martin Company, for the United States Department of Energy.

Access

Author: John C. Wiles, Southwest Technology Development Institute, New Mexico State University,

Box 30,001/ MSC 3 SOLAR, Las Cruces, NM 88003
505-646-6105 • Fax: 505-646-3841 • jwiles@nmsu.edu

Sponsor: Sandia National Laboratories, Ward Bower,
Department 6218, PO Box 5800 MS 0753,
Albuquerque, NM 87185-0753 • 505-844-5206
Fax: 505-844-6541 • wibower@sandia.gov

National Electrical Code[®] and *NEC*[®] are registered trademarks of the National Fire Protection Association. The 1999 *NEC* and the *NEC Handbook* are available from the NFPA, 11 Tracy Drive, Avon, MA 02322
800-344-3555 or 508-895-8300 • Fax: 800-593-6372 or 508-895-8301 • custserv@nfpa.org • www.nfpa.org

Soares Book on Grounding, US\$38.95 postpaid in the U.S. from International Association of Electrical Inspectors, 901 Waterfall Way, Suite 602, Richardson, TX 75080-7702 • 800-786-4234 or 972-235-1455
Fax: 972-235-6858 • iaei@compuserve.com
www.iaei.com

Wiles, J. C. and Bower, W. I., *Analysis of Grounded and Ungrounded Photovoltaic Power Systems*, First World Conference on Photovoltaic Energy Conversion, Hawaii, 1994

