

Making the Utility Connection for Larger Systems

John Wiles

Sponsored by the U.S. Department of Energy

As state and federal incentives continue and proliferate, larger photovoltaic (PV) systems are being installed on residences. The *National Electrical Code (NEC)* establishes how and where a utility-interactive PV system may be connected to the utility system. The point of connection for these systems may be either on the *load* (structure) side of the service disconnect or the *supply* (utility) side of the service disconnect.

Often, larger PV systems cannot be conveniently installed on the load side by using backfed circuit breakers in an existing load center. In many cases, the complex requirements for load-side connections [Section 690.64(B)(2)] are impractical and dictate that the utility-interactive inverter be connected on the supply side of the service disconnect.

This column concentrates on the requirements of the 2005 *NEC*, Section 690.64(A), Point of Connection, which allows residential PV installations to be connected to the *supply* side of the service disconnect. Making code-compliant *load* side connections to the utility grid for smaller PV systems was covered in *Code Corner*, HP111. Here are some, but not all, of the major code sections that address supply side connections. They apply to either a residential or commercial installation.

Supply Side Connections Allowed

Section 690.64(A) allows a supply (utility) side connection, as permitted in Section 230.82(6). In that section, photovoltaic systems are listed as equipment that is *permitted* for connection to the supply side of the service disconnect. The word "permitted" indicates an optional requirement.

The connection of a utility-interactive inverter to the supply side of a service disconnect is essentially connecting a second service-entrance disconnect to the existing service. Many, if not all, of the rules for service-entrance equipment must be followed.



This 30 KW PV system requires a supply-side utility connection.

Rules for Service-Entrance Conductors

Section 240.21(D) allows the service conductors to be tapped and refers to Section 230.91. These service-entrance tap requirements are not the same as the general feeder tap rules found elsewhere in the code. Section 230.91 requires that the service overcurrent device be co-located with the service disconnect. A circuit breaker or a fused disconnect would meet these requirements. A utility-accessible, visible break, lockable (open), fused disconnect (safety switch), if used, may also meet utility requirements for an external PV AC disconnect.

Section 230.71 specifies that the service disconnecting means for each set of service-entrance conductors shall be a combination of no more than six switches and sets of circuit breakers mounted in a single enclosure or in a group of enclosures. The addition of the photovoltaic equipment disconnect would be counted as one of the six.

Section 230.70(A) establishes the location requirements for the service disconnect. These are similar to the requirements for locating the PV DC disconnect. The disconnect must be in a readily accessible location, near

the point of entrance of the service conductors. The local jurisdiction will determine if it is to be inside or outside the building.

Section 705.10 requires that a directory be placed showing the location of all power sources for a building. Locating the PV service disconnect adjacent or near the existing service disconnect may facilitate the installation, inspection, and operation of the system.

Disconnects Rated at 60 Amps

Section 230.79(D) requires that the disconnect must have a minimum rating of 60 amps. This would apply to a service-entrance-rated circuit breaker or fused disconnect.

Section 230.42 requires that the service-entrance conductors be sized at 125 percent of the continuous loads. (All currents in a PV system are worst-case continuous.) The actual rating should be based on 125 percent of the rated output current for the utility-interactive PV inverter [690.8]. The disconnect must have a 60-amp minimum rating. Larger conductors may be required after temperature and conduit fill factors have been applied.

For a small PV system (for example, a 2,500-watt, 240-volt inverter requiring a 15-amp circuit and overcurrent protection), these requirements would appear to specify a minimum 60-amp rated disconnect, but 15-amp fuses could be used; fuse adapters would be required. While 15-amp conductors could be used between the inverter and the 15-amp fuses in the disconnect, Section 230.42(B) requires that the conductors between the service tap and the disconnect be rated not less than the rating of the disconnect—in this case, 60 amps.

How to deal with the 60-amp disconnect, 15-amp overcurrent requirements using circuit breakers is not as straightforward. A circuit breaker rated at 60 amps would serve as a disconnect, and it could be connected in series with a 15-amp circuit breaker to meet the inverter overcurrent device requirements. In this case, the requirements of 690.64(B)(2) should be applied for the series connection. See *Code Corner*, HP111 for details.

Check Available Fault Currents

Section 110.9 requires that the interrupt capability of the equipment be equal to the available fault current. The interrupt rating of the new disconnect-overcurrent device should at least equal the interrupt rating of the existing service equipment. The utility service should be checked to ensure that the available fault currents have not been increased above the rating of the existing equipment. Fused disconnects with RK-5 fuses are available with interrupt ratings up to 200,000 amps.

Section 230.43 allows a number of different service-entrance wiring systems. However, considering that the tap conductors are unprotected from faults, the conductors should be as short as possible, with the new PV service disconnect mounted adjacent to the tap point. Conductors installed in rigid metal conduit would provide the highest level of fault protection. All equipment must be properly grounded per Article 250 requirements.

Where to Make the Tap

The actual location of the tap will depend on the configuration and location of the existing service entrance equipment. The following connection locations have been used on various systems throughout the country.

On smaller residential and commercial systems, there is sometimes room in the main load center to tap the service conductors just before they are connected to the existing service disconnect. In other installations, the meter socket has lugs that are listed for two conductors per lug. Combined meter-service, disconnects-load centers frequently have significant amounts of interior space where the tap can be made between the meter socket and the service disconnect. Of course, adding a new pull box between the meter socket and the service disconnect is always an option. In larger commercial installations, the main service-entrance equipment will frequently have bus bars that have provisions for tap conductors.

Be Safe

In all cases, safe working practices dictate that the utility service be de-energized before any tap connections are made. The utility company will have to disconnect and de-energize the electrical service to the house. In most cases, the meter will be pulled from the socket.

Additional service-entrance disconnect requirements in Article 230 and other articles of the *NEC* apply to this connection. An electrician with experience in installing service-entrance equipment should make these types of PV-utility interconnections.

The requirements of *NEC* Section 690.64 can be met in nearly all installations. While the requirements, at first glance, are somewhat complex and sometimes overlooked, attention to these details in the design, installation, and inspection of these systems should help to ensure a safe, durable, and code-compliant installation.

Supply Side of Service Disconnect

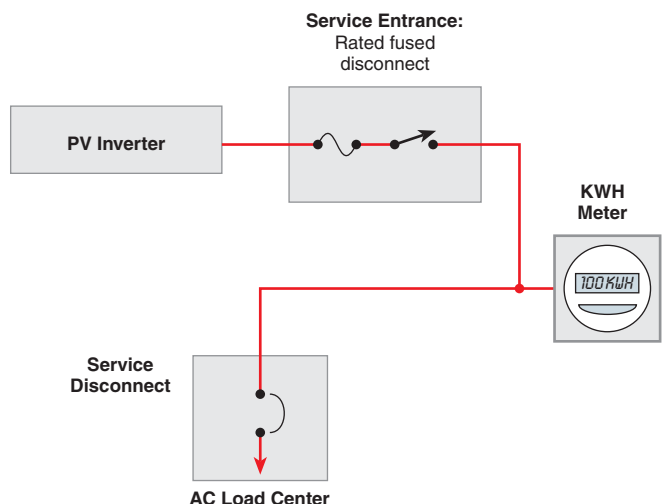

Questions or Comments?

If you have questions about the NEC or the implementation of PV systems that follow the requirements of the NEC, feel free to call, fax, e-mail, or write me. See the Web sites (below) for more detailed articles on these subjects. The U.S. Department of Energy sponsors my activities in this area as a support function to the PV industry under Contract DE-FC 36-05-G015149.

Access

John C. Wiles, Southwest Technology Development Institute, New Mexico State University, Box 30,001/ MSC 3 SOLAR, Las Cruces, NM 88003 • 505-646-6105 • Fax: 505-646-3841 • jwiles@nmsu.edu • www.nmsu.edu/~tdi

Photovoltaic Power Systems & the 2005 National Electrical Code: Suggested Practices, a downloadable 144-page PDF manual • www.nmsu.edu/Research/tdi/public_html/Photovoltaics/Codes-Stds/PVnecSugPract.html

2008 NEC proposals PDF • www.nmsu.edu/~tdi/pdf-resources/2008NECproposals2.pdf

Sandia National Laboratories, Ward Bower, Sandia National Laboratories, Dept. 6218, MS 0753, Albuquerque, NM 87185 • 505-844-5206 • Fax: 505-844-6541 • wibower@sandia.gov • www.sandia.gov/pv

The 2005 NEC and the NEC Handbook are available from the National Fire Protection Association (NFPA), 11 Tracy Dr., Avon, MA 02322 • 800-344-3555 or 508-895-8300 • Fax: 800-593-6372 or 508-895-8301 • custserv@nfpa.org • 

PLASTIC BATTERY BOXES

- HDPE WELDED-SEAM VENTED BOX WITH REMOVABLE LID
- SAFE & SECURE CONTAINMENT FOR LEAD-ACID BATTERIES
- UPS SHIPPABLE, CUSTOM SIZES

radiantsolartech.com
707-485-8359



PC Software for Sine Inverters

WinVerter™



OutBack Power Systems **xantrex**

www.RightHandEng.com (425) 844-1291



Independent Energy Systems

Our 21st Year Offgrid!
We provide excellent service & technical support.
Residential Power • Water Systems • Communications
Wind • PV • Hydro • Custom Design • Installation
All Major Brands



Don Loweberg
NABCEP Certified Installer

California Rebates!

OFF LINE
Located in the central Sierra, near Yosemite

e-mail: ofln@aol.com
www.psnw.com/~ofln
P.O. Box 231, North Fork, CA 93643

(559) 877-7080
CA Lic. #661052



11th North Country Sustainable Energy Fair & Home Tour

www.ncenergy.org
May 5, 6 & 7, 2006
SUNY Canton, Canton NY

- Workshops, Demonstrations and Exhibits
- Energy and Environmental Vendors
- Green Home Tours





Solar
Wind
Biodiesel
Geothermal
Fuel Cells
Climate Change
Peak Oil
Strawbale and Cordwood Masonry
Do-It-Yourself Weatherization
State Energy Incentive Programs
Green Building
Off-Grid Living
Ecological Footprint

Coordinated By:



ces
Community Energy Services Inc.
Phone: 315-379-9466

