

Making the Utility Connection

Perspectives on PV

A series of articles on photovoltaic (PV) power systems and the *National Electrical Code* by John Wiles

More than 90 percent of the new PV systems being installed throughout the United States are connected to the local utility with utility-interactive inverters (figure 1). These inverters range in size from about 250 watts (rated ac output) to about 250 kW. Multiple inverters may be used at a single location to provide even higher outputs. The connection requirements to the utility are established in various sections of the *Code*. Unfortunately, in many cases, these requirements are not fully understood or complied with. This article will concentrate on the requirements

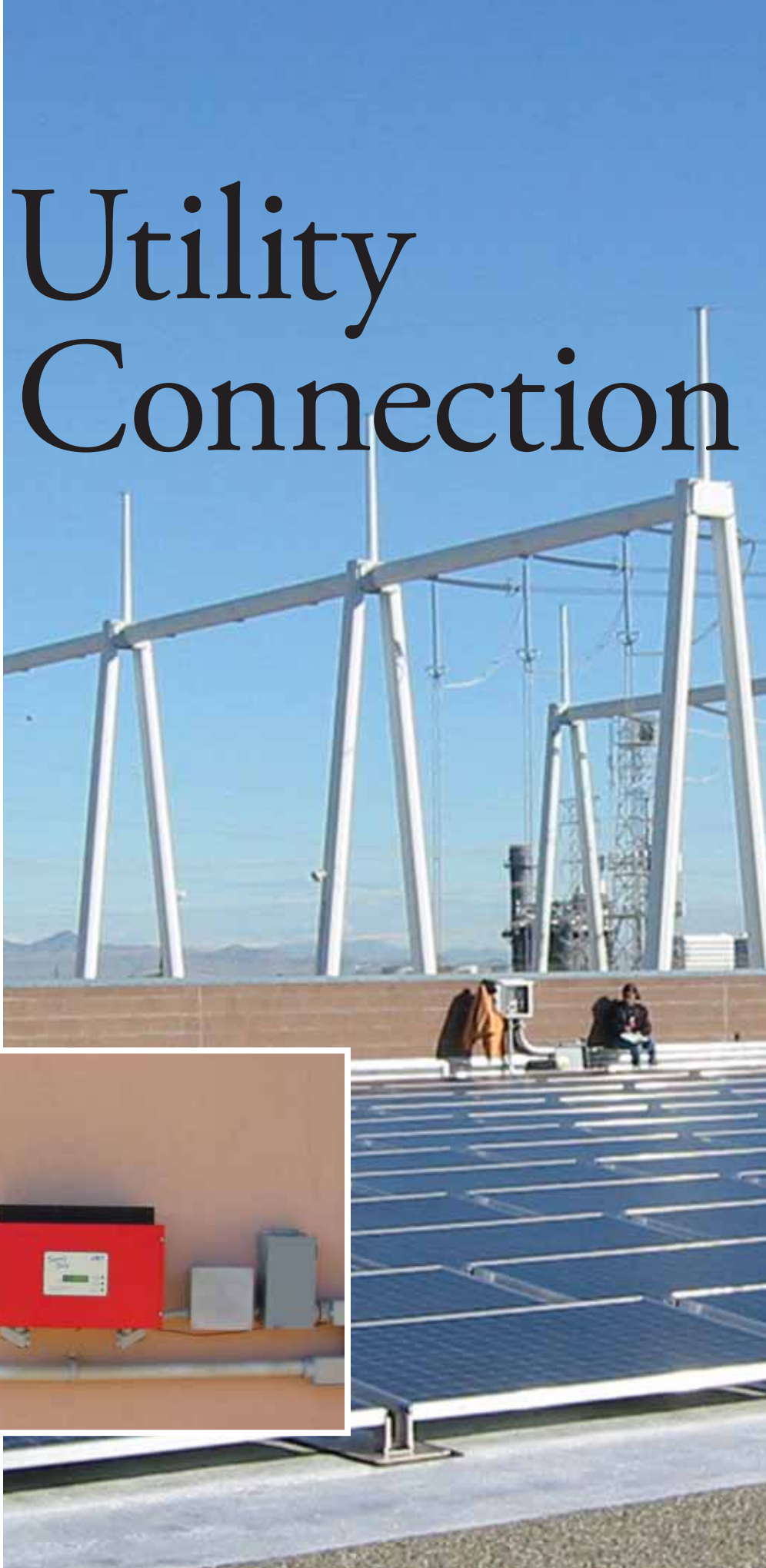

Figure 1. Utility-interactive inverter

of the *2005 National Electrical Code* Section 690.64, Point of Connection.

This section of the *Code* allows the output of the inverter to be connected either on the supply (utility) side of the service disconnect or on the load (inverter) side of the service disconnect. Supply-side and load-side connections will be addressed for non-dwelling (commercial) installations first, followed by the requirements for dwellings.

Supply-Side Connections—690.64(A)

Connecting to the supply side of the service disconnect usually implies that the output of the PV inverter is connected to the conductors between the service disconnect and the meter socket. This connection is made to allow the meter to sense utility-generated power flowing to the load (facility) and PV-generated power flowing back to the utility when local power production exceeds local loads. Using a single meter allows relatively easy implementation of net metering where the meter runs forward and backward (depending on power flow) and the customer eventually pays for only the net energy used or produced. Figure 2 shows a diagram of such a connection, and figure 3 shows the picture. In the picture, the disconnect shown is an existing feeder disconnect (1980s vintage) for the building and the connections for the PV conductors are at the bottom, which are on the supply side of the service disconnect for the building. The conductors leading into the building connect to the building load center that has a main circuit breaker serving as the service-entrance disconnect.

The inverter will normally be connected through a disconnect/overcurrent protection device before being connected to the service-entrance conductors between the meter and the service disconnect. This is equivalent to connecting a second service entrance to the building and the disconnect/overcurrent device (circuit breaker or fused disconnect) should be rated as service-entrance equipment. Elsewhere, Article 690 requires that the output circuit from the inverter be sized and protected at 125 percent of the rated continuous ac output of the inverter. Obviously, the existing service-entrance conductors must be at least this size in case they have to handle the full rated output of the PV system. Like other service conductors, the conductors between the disconnect/overcurrent device and the existing service-entrance conductors are not pro-

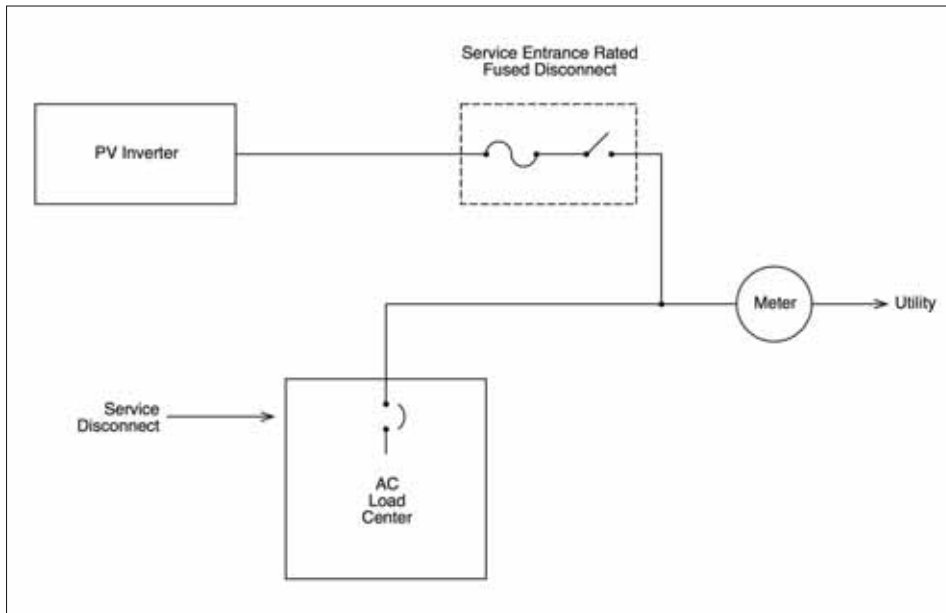

Figure 2. Supply-side interconnection diagram

tected, and it is suggested that they be as large as the disconnect/overcurrent device terminals will accept. It is also suggested that these conductors be kept as short as possible and that they follow the general requirements for service-entrance conductors. Since the inverter output circuit is not a load or feeder circuit, I do not believe that the general tap rules are applicable.

Of course, the connection could be made with the addition of a new meter, and this would be a complete



Figure 3. PV inverter output connected to service conductors

second service entrance to the facility. Usually, this complicates the measuring and billing for energy used or produced where net metering is in effect and the system is associated with a building or structure. However, this complete separate service entrance is frequently used on the larger (100 kW and up) systems.

Since many utilities require a visible blade, lockable (open) disconnect between the output of the inverter and the utility point of connection, the disconnect described above and required by the *NEC*, may also serve as the utility-required disconnect. In some cases, the utility will not allow a fused disconnect, so a second, non-fused disconnect must be added.

described above and required by the *NEC*, may also serve as the utility-required disconnect. In some cases, the utility will not allow a fused disconnect, so a second, non-fused disconnect must be added.

Load-Side Connections—690.64(B)

Load-side connection requirements are more numerous than supply-side connection requirements. Section 690.64(B)(1) requires that a dedicated circuit breaker or fused disconnect be used for the interconnection. This essentially means that the output of each single inverter be connected to a disconnect/overcurrent device before that circuit is connected to any other sources or loads. See figure 4 for a circuit showing two inverters connected to a load center (panelboard) on dedicated circuits. Figure 5 shows a picture of a load center being used to connect two utility-interactive inverters to the grid. And, yes, those circuits are “dead.”

The requirements of 690.64(B)(2) are complex. Here is what the section (without the exception) says with emphasis added by the author. “The sum of the ampere ratings of overcurrent devices in circuits *supplying* power to a busbar or conductor shall not exceed the rating of the busbar or conductor.”

The key word that many readers miss is the word “supplying.” In a load center or panelboard, the main circuit breaker *supplies* power to the internal busbars, as do any backfed circuit breakers *supplying* power from the PV inverters. The potential problem can be seen in figure 4. The load center is rated at 100 amps, the main circuit breaker can supply 100 amps to the busbars, and at the same time, the inverters may add another

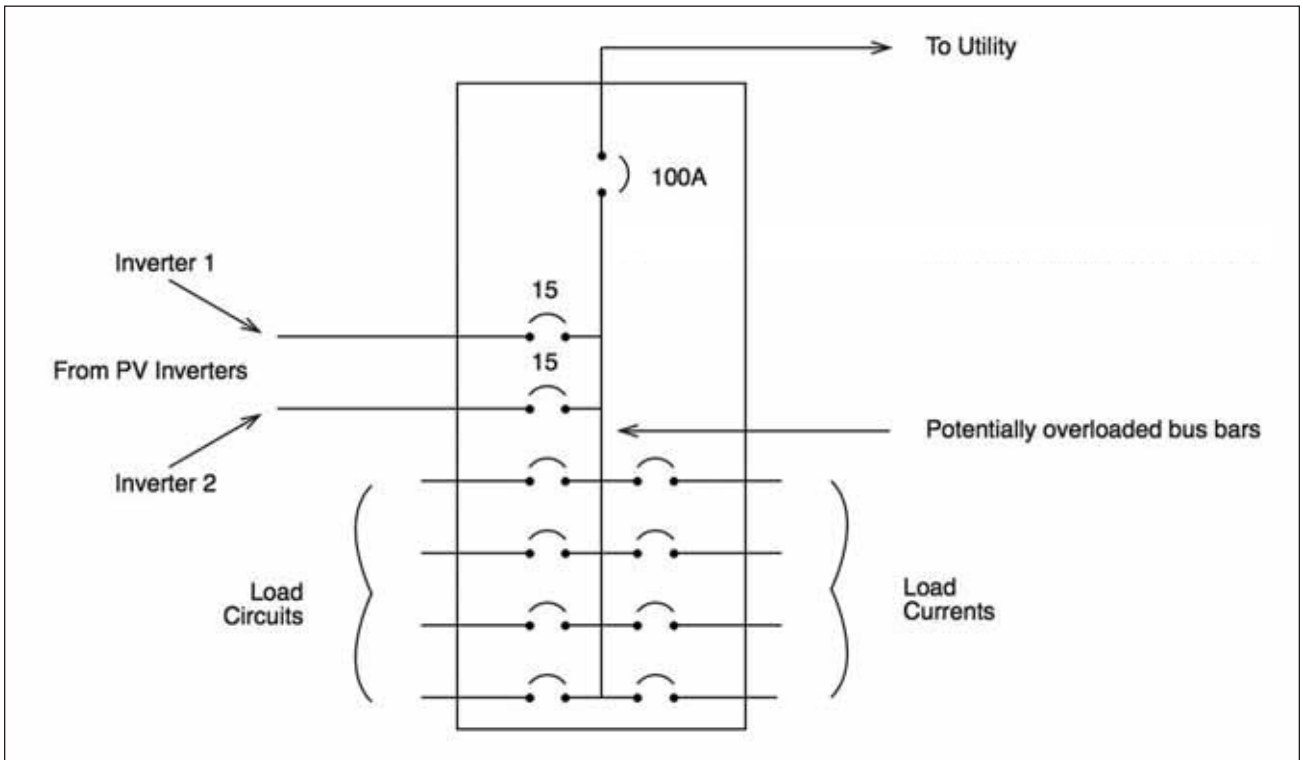

Figure 4. Load-side interconnection diagram

30 amps to the busbars. If the loads were increased to 130 amps (for example, increased plug loads), no circuit breakers would trip, but the busbars in the center of the panel rated at 100 amps would be overloaded carrying 130 amps.

In the deliberations for the *2002 NEC*, the determination was made that while placing the backfed PV circuit breakers at the bottom of the panel (as far away from the main circuit breaker as possible) would prevent overloading the panel busbars, it was not an acceptable long-term solution (even with placards). Placards get lost or damaged and people who may not be familiar with PV installations and interconnections move around circuit breakers in load centers after the initial installation.

In designing PV systems for commercial (non-dwelling) installations, an existing load center is usually considered. In many commercial installations, the size of the main circuit breaker in the load center has the same rating as the load center itself. Therefore *no* additional current may be supplied to the load center from backfed PV circuit breakers. In this case, one alternative is to go to a supply-side connection as outlined above. Another option is to remove the existing load center and replace it with a new, larger load center that has a main circuit breaker rated the same as the original main circuit breaker. The amount of PV current that can be backfed

is the difference between the panel rating and the main circuit breaker.

In all cases the main circuit breaker, the load center, and any conductors (including feeders) carrying the output of a PV system must be sized for at least 1.25 x the rated output of the inverter (see 690.8 and 690.9). As will be seen below, the load center will usually be significantly larger than just the size required by the PV circuits.



Figure 5. The author, right, and Albuquerque, NM, Electrical Inspection Supervisor Hal Kissinger inspecting a load-side connection

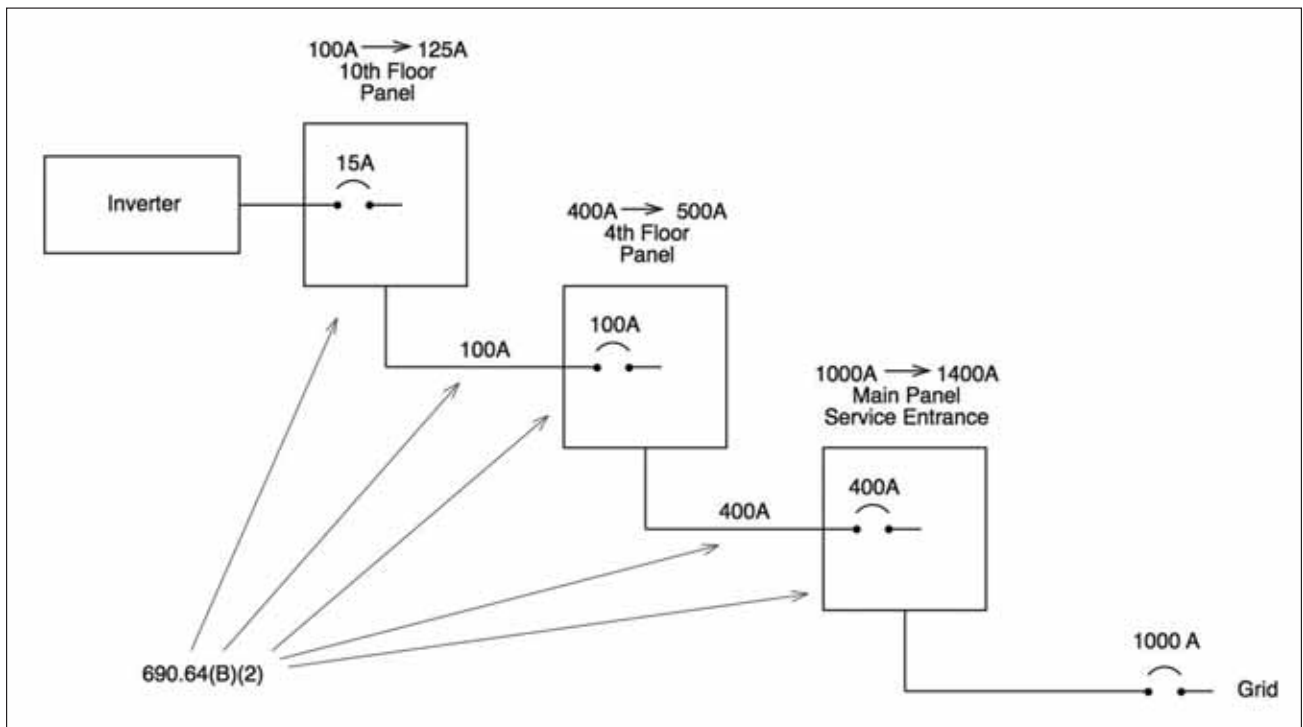

Figure 6. Multiple feeder panel connection diagram

In some installations, an oversized load center is being used with an adjustable main circuit breaker. Assuming that the main circuit breaker is set at a trip point below the rating of the panel, then the difference between the two ratings is the allowable current that can be backfed from the PV array.

It is usually *not* a good idea to replace an existing main circuit breaker with one that has a lower rating or to adjust an adjustable main to a lower trip point in an attempt to accommodate a PV system. The original installer of the system sized that main circuit breaker based on code-required load calculations, and if the circuit breaker rating were changed, it could result in nuisance trips or an overloaded circuit breaker, not to mention a *Code* violation.

Connecting PV Systems to a Commercial Feeder Panel or Subpanel

In many commercial installations, the PV system is installed on the roof of a multi-story building. The building usually has a feeder panel or subpanel on each floor of the building, and those panels are connected to a main panel on the ground floor. To minimize the PV installation cost, an attempt is made to connect the PV output to the feeder panel on the top floor. However, figure 6 reveals a problem. While the requirements of 690.64(B)(2) are easily met at the top floor feeder panel, they become increasingly more

difficult to meet at intermediate feeder panels and at the main panel.

For example, the backfed PV current at the top floor 100-amp feeder panel could require only a 15-amp circuit breaker. Section 690.64(B)(2) would normally require that the feeder panel be increased to 125 amps (next standard size) to accommodate the 15-amp backfed PV circuit breaker. However, when we get to the first 400-amp intermediate panel, the rating of the backfed circuit breaker carrying the PV currents is now 100 amps, not the 15-amp rating of the circuit breaker in the top floor panel. Meeting 690.64(B)(2) is more difficult with the larger backfed circuit breaker. Since this 100-amp circuit breaker is the only circuit breaker limiting backfed currents, its full 100-amp rating must be considered, not just the 15-amps that it is carrying at the present time. If only the 15 amps were considered, then at some future date the PV array might be expanded and the intermediate feeder panels could be overloaded since any backfed currents could reach 100 amps before a circuit breaker tripped in the intermediate 400-amp panel. At this point, the 400-amp panel would have to be increased to at least a 500-amp panel to accommodate the 100-amp backfed circuit breaker to meet 690.64(B)(2) requirements.

The same analysis applies to the main 1000-amp panel. The backfed circuit breaker is now rated at 400 amps and to meet *Code*, the main panel would have to be upgraded

to at least a 1400-amp panel to keep the 1000-amp main circuit breaker. All of these difficulties could be avoided by doing a supply-side connection (at 15 amps). Of course, those 15-amp PV output circuit conductors would have to be routed from the roof to the main service panel, and the output voltage of the inverter would have to match the voltage of the service entrance. In some cases a transformer might be required to match the inverter output voltage to the service-entrance voltage.

In all cases, connecting a second service-entrance disconnect with a 15-amp rating (probably using a higher-rated disconnect) to an existing 1000-amp service must, of course, be accomplished in a safe, code-compliant manner using appropriate equipment.

Applying 690.64(B)(2) to the feeder conductors carrying backfed PV currents between the various panels indicates that they usually will not have to be enlarged in size when a PV system is added. There is no place on these circuits where the feeder can be overloaded (unless the PV output current exceeds the feeder rating) because there are no places between circuit breakers where loads can be connected that could be inadvertently increased as they could be inside a panel board as shown in figure 1.

Supply-Side Connections— 690.64(B)(2) Dwelling Units

Now, let us examine the installation requirements for dwelling units. The exception for 690.64(B)(2) reads: “For a dwelling unit, the sum of the ampere ratings of the overcurrent devices shall not exceed 120 percent of the rating of the busbar or conductor.”

Now we can add PV backfed circuit breakers to the dwelling (residential) load center with some leeway before we have to start changing equipment. Normally, the main circuit breaker in a residential load center is rated the same as the residential load center. This exception allows the sum of the main circuit breaker plus the sum of any backfed PV circuit breakers to be 120 percent of the rating of the load center. This additional 20 percent allowance is made because, generally, residential circuits are more lightly loaded (due to demand factor calculations) than circuits in commercial buildings. Where the main circuit breakers and panels have the same rating, the exception to 690.64(B)(2) allows 20 amps of backfed PV circuit breakers to be added to a 100-amp panel and 40 amps to be added to a 200-amp panel. Although these numbers translate to a 3840-watt (ac inverter output) PV system on a 100-amp panel and a 7680-watt PV system on a 200-amp panel, some people want to

install bigger PV systems and that means creative thinking must be used. These limits include the normal 80 percent maximum continuous operating-current limitations on the circuit breakers.

Many common PV inverters are rated at 2500 watts, 240 volts. The rated output current is $2500/240 = 10.4$ amps. Using the code-required 1.25 multiplier (690.8) yields a circuit breaker requirement of 13 amps, which rounds up to 15 amps as the rating of the backfed circuit breaker. On a 100-amp panel, with a 100-amp main circuit breaker, only one of these inverters can be accommodated. On a 200-amp panel, only two of these inverters may be connected limiting the PV system to 5000 watts and not the maximum potential of 7680 watts.

However, figure 7 shows a code-compliant way to add three of these 2500-watt inverters to a 200-amp panel by using a subpanel. A subpanel is selected to accommodate the three 15-amp backfed circuit breakers, one from each of the 2500-watt inverters. The main circuit breaker on this dedicated (PV-only) subpanel has to have a minimum rating of the $3 \times 10.4 \times 1.25 = 39$ amps (round up to a 40-amp circuit breaker). This would also be the rating of the backfed circuit breaker in the main panel and, at 40 amps, would meet the *Code* requirements for a 200-amp main panel. Of course, two 40-amp circuit breakers would not be needed, and only one at the main panel would suffice.

What should the size of the subpanel be? Using a formula derived from the *Code* requirements, we see that the minimum size of the panel would be about 75 amps, which would round up to a 100-amp, standard-sized panel.

$3 * 15 + 40 \leq 1.2 X$, where X is the panel size required

Solving for X gives us

$$X \geq (45 + 40)/1.2 = 71 \text{ amps}$$

For those desiring to install larger PV systems on residential services, the use of a supply-side connection as outlined above can meet the *Code* requirements.

Line Side of Ground Fault Equipment—690.64(B)(3)

The *Code* generally requires that all PV inverters be connected on the line side of any ground-fault protection equipment with an exception that allows backfed GFP equipment when the protected circuits have ground-fault protection from all sources.

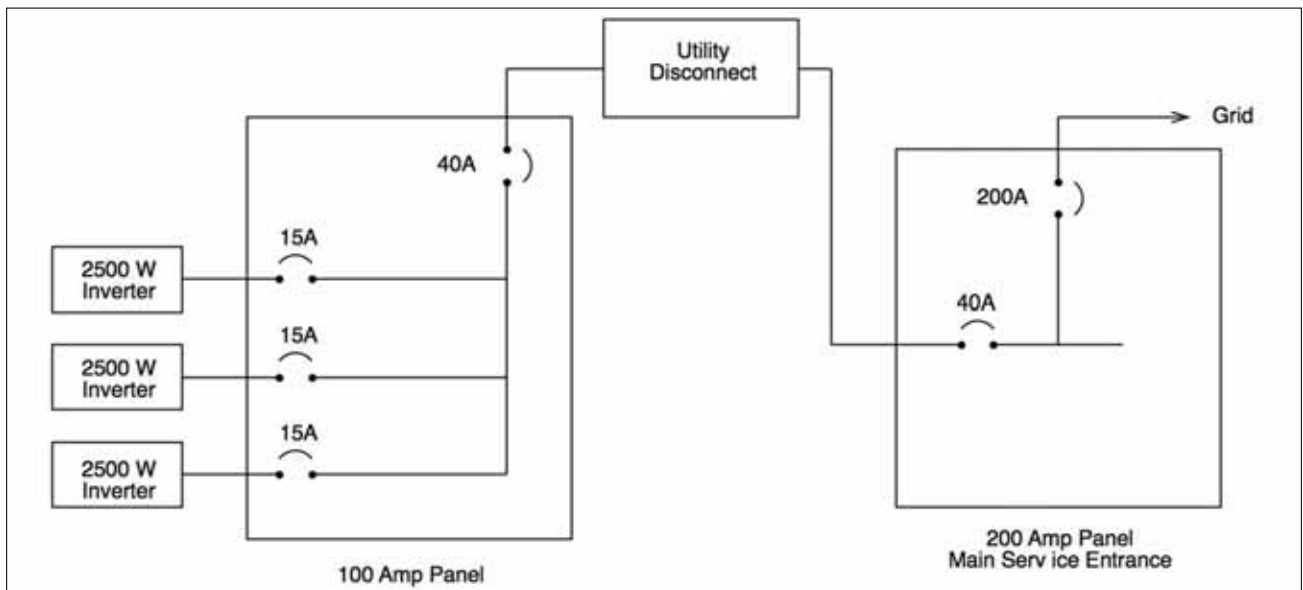

Figure 7. Three 2500-watt inverters on a 200-amp residential panel

However, tests (by SWTDI and Sandia National Laboratories) on the typical 5 milliamp GFCIs, 5 and 30 milliamp GFP circuit breakers have revealed that the internal sensing and trip circuits are destroyed when they are tripped while being backfed by a PV inverter. Conversations with manufacturers of the larger 100–800-amp ground-fault protection devices also indicate that these devices will be damaged when tripped while being backfed. Therefore, it is recommended that ground-fault protection equipment never be backfed. A proposal deleting the exception to 690.64(B)(3) is being developed for the 2008 NEC.

Markings Required—690.64(B)(4)

This section requires that all panelboards and fused disconnects supplying power to a busbar or conductor be marked showing all sources of power. This requirement is generally met by the installation of placards containing the required information installed by the system installer on all backfed panelboards and fused disconnects. The placard should show the rated output current of the inverter feeding the circuit and the nominal line voltage of the inverter.

Backfed Circuit Breakers—690.64(B)(5)

Although another section of the Code [408.36(F)] requires that backfed circuit breakers be clamped, changes to 690.64(B)(5) in the 2005 NEC no longer require them to be clamped when connected to the output of utility-interactive inverters. Section 690.3 indicates that the 690 requirements override the 408 requirement. A fine print note explains that circuit breakers suitable

for backfeeding *are not* marked with “Line” and “Load” designations.

Battery-Backed-Up, Utility-Interactive Systems—More Complexity

The specifications in Underwriters Laboratories Standard 1741 require all utility-interactive inverters cease exporting power to the utility grid when the utility grid voltage and frequency deviate from very narrowly defined values. In blackout situations, the PV system and the standard utility-interactive inverter cease to operate and will not even supply power to local loads. In areas where utility blackouts are common or are anticipated to be common, some systems are being installed that have a battery-based energy storage system installed to provide local power during utility outages. The batteries are connected to a specially designed and listed utility-interactive inverter that, in the event of a utility outage, will disconnect from the utility system and provide a set of designated circuits with power from the PV system and the battery. All of these actions are done automatically with transfer devices built into the inverter. Figure 8 shows a simplified block diagram of a typical system. Several variations are possible.

In normal operation, the utility is present and the inverter acts as any other utility-interactive inverter. Any power from the PV system in excess of local load requirements is fed into the utility grid. When insufficient power is available from the PV system, the system buys power from the utility. The batteries are kept at full charge (float charged) by the utility power and are generally not used. However, when there is a utility out-

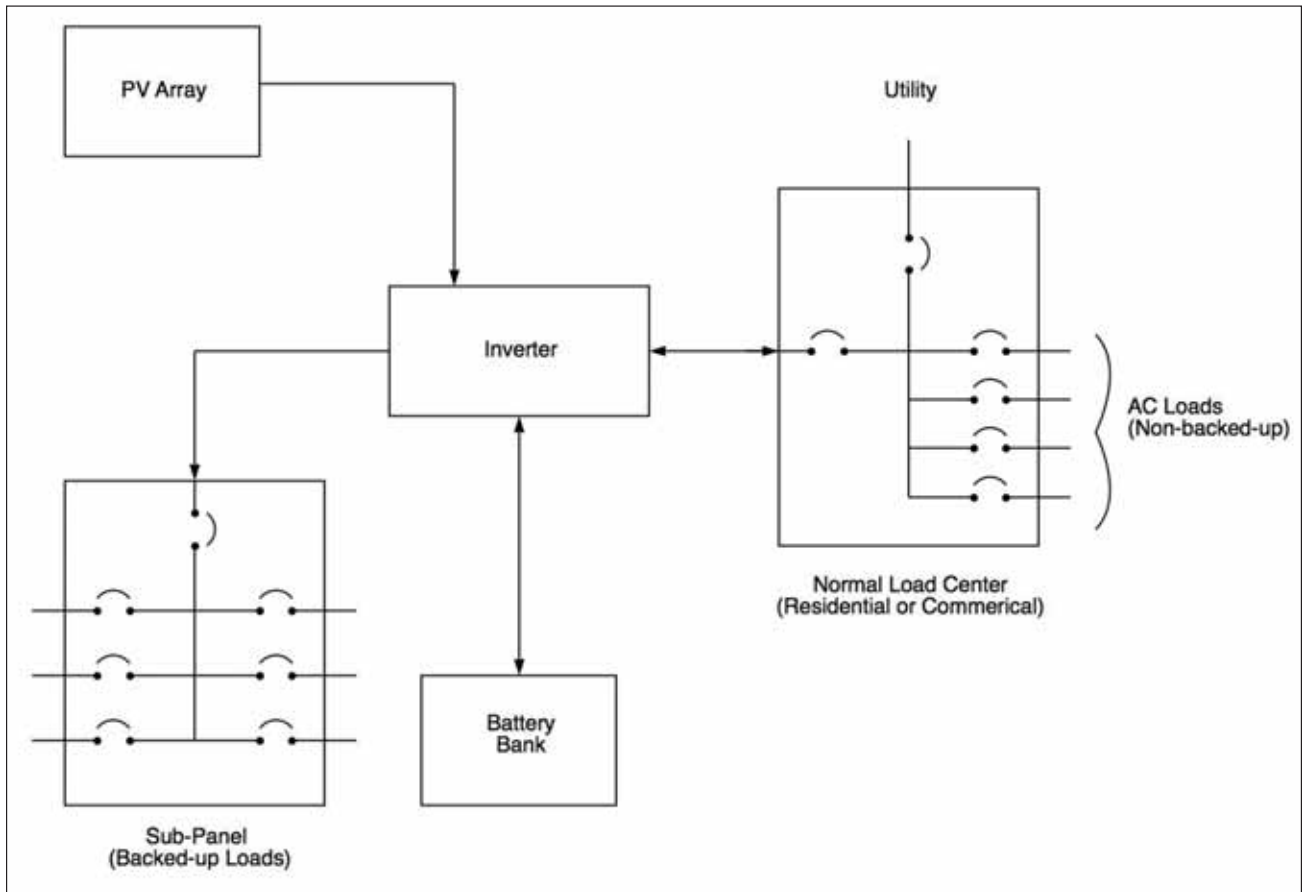

Figure 8. Utility-interactive PV system with battery backup

age, the inverter automatically senses this outage, ceases to export power to the utility, and feeds the backup load subpanel with ac power derived from the PV array and the batteries. The backup loads will receive ac power from the batteries and PV array to the extent that the energy draw does not exceed the capacity of the supply and storage systems.

Interfacing these systems with the utility grid and meeting 690.64(B)(2) requirements presents challenges for the system designer, the installer, and the inspector. Many of these inverters have internal transfer relays that are rated for 60-amps continuous duty, and that information is presented in the specifications. This specification leads designers and installers to size the backup load subpanel for 60 amps and to use a 60-amp backfed circuit breaker to connect the inverter to the main load center where the utility connection is made. The use of 60-amp circuit breakers in both positions provides for best use of the internal 60-amp relay and appears to allow maximum loads to be connected to the backup subpanel. Unfortunately, the use of 60-amp circuit breakers poses two problems and *Code* violations.

First, even though the inverter may be rated (and can

be adjusted) to carry 60 amps, the external wiring and circuit breakers require the normal 80 percent continuous current derating. For a 60-amp continuous current, an 80-amp circuit breaker and conductors rated for at least 75 amps would be required. Another option, that will allow the 60-amp circuit breakers to be retained, would be to adjust the inverter to not allow more than 48 amps of continuous current to be handled by these circuits. That adjustment is commonly available on most of these inverters, although there is some question about who has access to the adjustment (qualified or unqualified people).

A second issue is the 690.64(B)(2) requirements discussed above. In a residential installation, a 60-amp backfed PV circuit breaker would dictate that at least a 300-amp main panel be used (60 amp PV circuit breaker + 300 amp main circuit breaker = 360 amps = $1.2 \times 300 = 360$). Residential load centers rated at 300-amps and above, while not impossible, are not common. In a commercial installation, the existing load center would have to be replaced with one having at least a 60 amp greater rating. In either case, a supply-side interconnection [690.64(A)] might be the more practical alternative.

If the full 60 amps of the inverter are to be used, then, of course, 80-amp circuit breakers and 75-amp conductors should be used.

To further complicate the system design, many of these systems have an external inverter-bypass switch that is used if the inverter fails. This bypass switch, usually consisting of a pair of interlocked circuit breakers, is used to connect the back up subpanel directly to the main panel when the inverter fails. These circuit breakers are typically also rated at 60 amps and installed in a small 60-amp, three-position (three-phase) load center. Obviously neither the circuit breakers nor the load center are rated to carry 60-amps continuously. The use of a larger load center and interlocked 80-amp circuit breakers would allow a full 60-amp rating for the inverter-bypass switch.

Summary

The requirements of *NEC* Section 690.64 can be met in nearly all installations. While the requirements, at first glance, are somewhat complex and sometimes overlooked, attention to these details in the design, installation, and inspection of these systems should help to ensure a safe, durable, and code-compliant installation.

For Additional Information

If this article has raised questions, do not hesitate to contact the author by phone or e-mail. E-mail: jwiles@nmsu.edu. Phone: 505-646-6105

A PV Systems Inspector/Installer Checklist will be sent via e-mail to those requesting it. A color copy of the 143-page, 2005 edition of the *Photovoltaic Power Systems and the National Electrical Code: Suggested Practices*,

published by Sandia National Laboratories and written by the author, may be downloaded from this web site: (<http://www.nmsu.edu/~tdi/roswell-8opt.pdf>.) A black and white printed copy will be mailed to those requesting a copy via e-mail if a shipping address is included. The Southwest Technology Development web site <http://www.nmsu.edu/~tdi> maintains all copies of the previous “Perspectives on PV” articles. Copies of “Code Corner” written by the author and published in *Home Power Magazine* over the last 10 years are also available on this web site.

Draft proposals for the *2008 NEC* being developed by the PV Industry Forum may be downloaded from this web site: <http://www.nmsu.edu/~tdi/pdf-resources/2008NECproposals2.pdf>

The author makes 6–8 hour presentations on “PV Systems and the *NEC*” to groups of 40 or more inspectors, electricians, electrical contractors, and PV professionals for a very nominal cost on an as-requested basis. A schedule of future presentations can be found on the SWTDDI web site.✍

John Wiles works at the Southwest Technology Development Institute (SWTDDI) at New Mexico State University. SWTDDI has a contract with the US Department of Energy to provide engineering support to the PV industry and to provide that industry, electrical contractors, electricians, and electrical inspectors with a focal point for code issues related to PV systems. He serves as the secretary of the PV Industry Forum that submitted 30 proposals for Article 690 in the 2005 NEC. He provides draft comments to NFPA for Article 690 in the NEC Handbook. As an old solar pioneer, he lives in a stand-alone PV-power home in suburbia with his wife, three dogs, and a cat—permitted and inspected, of course.

This work was supported by the United States Department of Energy under Contract DE-FC04-00AL66794.